



## Low-loss transmitter combiners

Model	Num. of channels	Diam of cavity	Loss, dB	TX-TX separ. MHz	Input power, W	Band, MHz	Price, EUR
CL8-3(2)LB(L)-150	3	8"	1,6	0,4	150	30-40	4626
CL8-3(2)LB(H)-150	3	8"	1.6	0.4	150	38-48	4062
CL8-2(2)FM-1,5	2	8"	0,8	3	1500	100-108	1553
CL8-2V-50-R/2	2	8"	2,8	0,125	50 "regular"	140-174	1620
CL8-2V-50-X/2	2	8"	2.8	0.125	50 "extreme"	140-174	1801
CL8-4V-50-R/2	4	8"	3,2	0,125	50 "regular"	140-174	3270
CL8-4V-50-X/2	4	8"	3.2	0.125	50 "extreme"	140-174	3632
CL8-6V-50-R/2	6	8"	3,5	0,125	50 "regular"	140-174	5671
CL-6V-50-X/2	6	8"	3.5	0.125	50 "extreme"	140-174	6215
CL8-8V-50-R/2	8	8"	3,8	0,125	50 "regular"	140-174	7561
CL-8V-50-X/2	8	8"	3.8	0.125	50 "extreme"	140-174	8286
CL8-2V-125-R/2	2	8"	2,8	0,125	125 "regular"	140-174	2587
CL8-2V-125-X/2	2	8"	2.8	0.125	125 "extreme"	140-174	2720
CL8-4V-125-R/2	4	8"	3,2	0,125	125 "regular"	140-174	5173
CL8-4V-125-X/2	4	8"	3.2	0.125	125 "extreme"	140-174	5439
CL8-6V-125-R/2	6	8"	3,5	0,125	125 "regular"	140-174	8005
CL8-6V-125-X/2	6	8"	3.5	0.125	125 "extreme"	140-174	8404
CL8-8V-125-R/2	8	8"	3,8	0,125	125 "regular"	140-174	10673
CL8-8V-125-X/2	8	8"	3.8	0.125	125 "extreme"	140-174	11205
CL8-2V-300	2	8"	2,8	0,125	300	140-174	3996
CL8-3V-300	3	8"	3	0,125	300	140-174	5993
CL10-2V-50-R/2	2	10"	2,6	0,1	50 "regular"	140-174	2181
CL10-2V-50-X/2	2	10"	2.6	0.1	50 "extreme"	140-174	2362
CL10-4V-50-R/2	4	10"	3.2	0,1	50 "regular"	140-174	4132
CL10-4V-50-X/2	4	10"	3.2	0.1	50 "extreme"	140-174	4494
CL10-6V-50-R/2	6	10"	3.4	0,1	50 "regular"	140-174	6080
CL10-6V-50-X/2	6	10"	3.4	0.1	50 "extreme"	140-174	6624
CL10-8V-50-R/2	8	10"	3.6	0,1	50 "regular"	140-174	8031
CL10-8V-50-X/2	8	10"	3.6	0.1	50 "extreme"	140-174	8756
CL10-2V-125-R/2	2	10"	2,6	0,1	125 "regular"	140-174	3058
CL10-2V-125-X/2	2	10"	2.6	0.1	125 "extreme"	140-174	3191
CL10-4V-125-R/2	4	10"	3.2	0,1	125 "regular"	140-174	5882
CL10-4V-125-X/2	4	10"	3.2	0.1	125 "extreme"	140-174	6148
CL10-6V-125-R/2	6	10"	3.4	0,1	125 "regular"	140-174	8710
CL10-6V-125-X/2	6	10"	3.4	0.1	125 "extreme"	140-174	9108
CL10-8V-125-R/2	8	10"	3.6	0,1	125 "regular"	140-174	11536
CL10-8V-125-X/2	8	10"	3.6	0.1	125 "extreme"	140-174	12068
CL12-2V-50-R/2	2	12"	2,5	0,075	50 "regular"	140-174	2401
CL12-2V-50-X/2	2	12"	2.5	0.075	50 "extreme"	140-174	2583
CL12-4V-50-R/2	4	12"	2,8	0,075	50 "regular"	140-174	4565
CL12-4V-50-X/2	4	12"	2.8	0.075	50 "extreme"	140-174	4927
CL12-6V-50-R/2	6	10"	3	0,075	50 "regular"	140-174	6701
CL12-6V-50-X/2	6	12"	3	0.075	50 "extreme"	140-174	7244
CL12-8V-50-R/2	8	12"	3,2	0,075	50 "regular"	140-174	8820
CL12-8V-50-X/2	8	12"	3.2	0.075	50 "extreme"	140-174	9544
CL12-2V-125-R/2	2	12"	2,5	0,075	125 "regular"	140-174	3284
CL12-2V-125-X/2	2	12"	2.5	0.075	125 "extreme"	140-174	3417
CL12-4V-125-R/2	4	12"	2.8	0.075	125 "regular"	140-174	6318
CL12-4V-125-X/2	4	12"	2.8	0.075	125 "extreme"	140-174	6584
CL12-6V-125-R/2	6	12"	3	0.075	125 "regular"	140-174	9324
CL12-6V-125-X/2	6	12"	3	0.075	125 "extreme"	140-174	9723
CL10-2A-50	2	10"	3,2	0,2	50	300-360	2076
CL10-4A-50	4	10"	3,6	0,2	50	300-360	3930
CL10-6A-50	6	10"	3,9	0,2	50	300-360	5777
CL10-8A-50	8	10"	4,2	0,2	50	300-360	7626
TETRA-4A	4	7"	3.6	0.125	50	300-360	4762
TETRA-8A	8	7"	4.5	0.125	50	300-360	8602

CL8-2UL-50-R/2	2	8"	2,8	0,3	50 "regular"	400-490	1620
CL8-2UL-50-X/2	2	8"	2.8	0.3	50 "extreme"	400-490	1801
CL8-4UL-50-R/2	4	8"	3,2	0,3	50 "regular"	400-490	3270
CL8-4UL-50-X/2	4	8"	3.2	0.3	50 "extreme"	400-490	3632
CL8-6UL-50-R/2	6	8"	3,4	0,3	50 "regular"	400-490	5671
CL8-6UL-50-X/2	6	8"	3.4	0.3	50 "extreme"	400-490	6215
CL8-8UL-50-R/2	8	8"	3,6	0,3	50 "regular"	400-490	7561
CL8-8UL-50-X/2	8	8"	3.6	0.3	50 "extreme"	400-490	8286
CL8-2UL-125-R/2	2	8"	2,8	0,3	125 "regular"	400-490	2584
CL8-2UL-125-X/2	2	8"	2.8	0.3	125 "extreme"	400-490	2720
CL8-4UL-125-R/2	4	8"	3,2	0,3	125 "regular"	400-490	5173
CL8-4UL-125-X/2	4	8"	3.2	0.3	125 "extreme"	400-490	5439
CL8-6UL-125-R/2	6	8"	3,4	0,3	125 "regular"	400-490	8005
CL8-6UL-125-X/2	6	8"	3.4	0.3	125 "extreme"	400-490	8404
CL10-2UL-50-R/2	2	10"	3.2	0,2	50 "regular"	400-490	2181
CL10-2UL-50-X/2	2	10"	3.2	0.2	50 "extreme"	400-490	2362
CL10-4UL-50-R/2	4	10"	3.4	0,2	50 "regular"	400-490	4132
CL10-4UL-50-X/2	4	10"	3.4	0.2	50 "extreme"	400-490	4494
CL10-6UL-50-R/2	6	10"	3.8	0,2	50 "regular"	400-490	6080
CL10-6UL-50-X/2	6	10"	3.8	0.2	50 "extreme"	400-490	6624
CL10-8UL-50-R/2	8	10"	4.2	0,2	50 "regular"	400-490	8031
CL10-8UL-50-X/2	8	10"	4.2	0.2	50 "extreme"	400-490	8756
CL10-2UL-125-R/2	2	10"	3.2	0,15	125 "regular"	400-490	3058
CL10-2UL-125-X/2	2	10"	3.2	0.15	125 "extreme"	400-490	3191
CL10-4UL-125-R/2	4	10"	3.4	0,15	125 "regular"	400-490	5882
CL10-4UL-125-X/2	4	10"	3.4	0.15	125 "extreme"	400-490	6148
CL10-6UL-125-R/2	6	10"	3.8	0,15	125 "regular"	400-490	8710
CL10-6UL-125-X/2	6	10"	3.8	0.15	125 "extreme"	400-490	9108
CL10-2UL-300	2	10"	3.2	0,15	300	400-490	4513
CL10-3UL-300	3	10"	3.3	0,15	300	400-490	6654
TETRA-2U	2	7"	2.6@0.3MHz	0.125	50	400-490	2419
TETRA-4U	4	7"	3.0@0.3MHz	0.125	50	400-490	4762
TETRA-8U	8	7"	3.5@0.3MHz	0.125	50	400-490	8602



## 30-48 MHz Low-loss transmitter combiner CL8-3(2)LB-150

107497, Moscow Chernicinsky pr-d 7/1  
Tel.: (495) 775-43-19, 462-44-14  
Tel./fax: 462-44-14  
E-mail: radial@radial.ru  
www.radial.ru



### Electrical specifications

Model	CL8-3(2)LB(L)-150	CL8-3(2)LB(H)-150
Operating frequency band, MHz	30-40	38-48
Insertion loss @ min. space, dB		1.5-2
Min. space TX/TX, kHz		400
Impedance, Ohm		50
Isolation TX-TX not less, dB		40
VSWR, not more than		1,5
Input power, W		not more than 150
Temperature range, °C		-30 to +60
Cavity electrical length		1/4λ

### Mechanical specifications

Model	CL8-3(2)LB(L)-150	CL8-3(2)LB(H)-150
Diameter of cavity, mm (ins.)		200x200 (8"x8")
Weight without rack, kg	130	101.6
Connector		N-female
Mount to 19-inch rack		yes

Due to the appearance at the market of new radio stations of the range LB many enterprises having at their disposal this unique frequency range are currently reviving the systems of mobile communications. The increase in the amount of radio stations at supervisory consoles has demanded more professional approach to the construction of antenna-feeder systems and application of this combiner. The coaxial resonators of enhanced quality-factor(Q-factor) of diameter 8" have been successfully applied by us in a new model of CL8-3(2)LB-150 combiner which has allowed providing the operation of three simplex radio stations for one antenna. The minimum frequency separation between the channels has made up 400 KHz and the isolation - nor less than 40 dB. The application of this combiner jointly with a new wideband antenna of the type GPW-1LB gives the possibility to add the significantly separated simplex frequencies.

### Low loss transmitter combiner CL8-3(2)LB-150

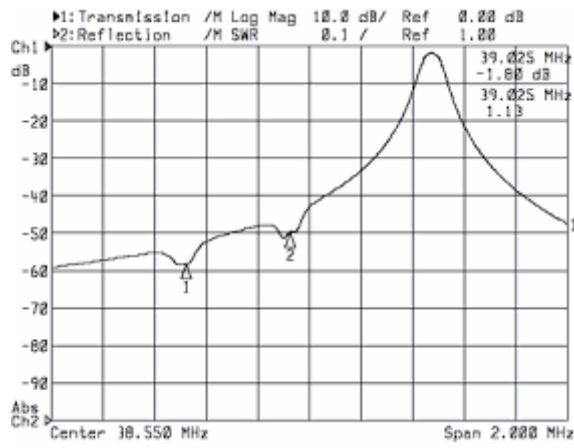
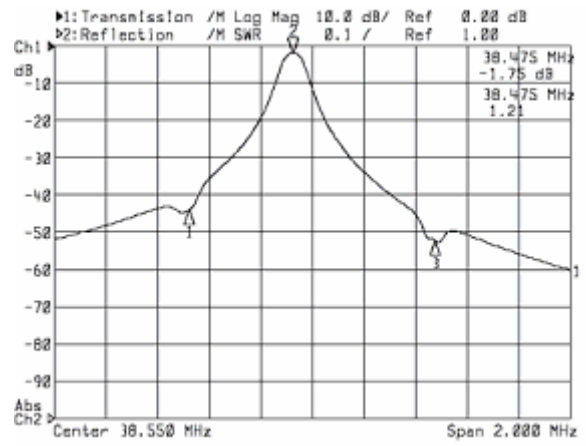
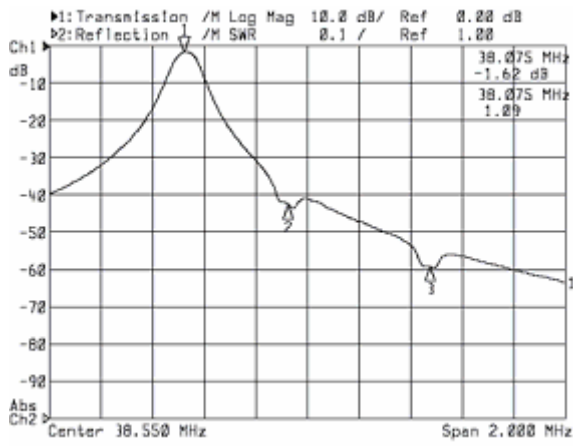



# 100-108 MHz Low-loss transmitter combiners CL8-2(2)FM-1,5

107497, Moscow Chernicinsky pr-d 7/1  
Tel.: (495) 775-43-19, 462-44-14  
Tel./fax: 462-44-14  
E-mail: radial@radial.ru  
www.radial.ru



Electrical specifications

Model	CL8-2(2)FM-1,5
Operating frequency band, MHz	100-108
Insertion loss @ min. space, dB	0,6
Min. space TX/TX, MHz	2,5
Impedance, Ohm	50
Isolation TX-TX not less, dB	30
VSWR, not more than	1,5
Input power, W	1500
Temperature range, °C	-30 to +60
Cavity electrical length	1/4λ

Mechanical specifications

Model	CL8-2(2)FM-1,5
Diameter, mm (ins.)	206 (8")
Weight without rack, kg	30
Connector in	N-female
Connector out	7/16 DIN
Mount to 19-inch rack	shipped with rack

**Typical selectivity characteristics CL8-2(2)FM-1,5**

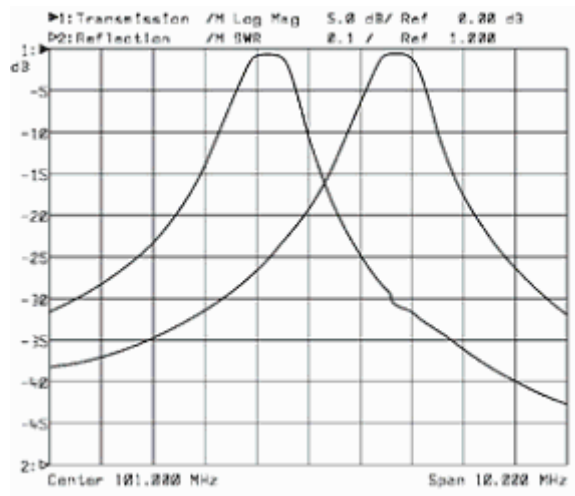



107497, Moscow Chernicinsky pr-d 7/1  
 Tel.: (495) 775-43-19, 462-44-14  
 Tel./fax: 462-44-14  
 E-mail: radial@radial.ru  
 www.radial.ru

## 140-174 MHz Low-loss transmitter combiners

CL8-4V-50X/2



CL10-8V-125X/2



CL10-4V-50X/2



### Electrical specifications

Model	Min. space TX/TX, kHz	Insertion loss @ min. space, dB	Input power, W	Cavity electrical length	Diameter of cavity, mm (ins.)	Weight without rack, kg	Mount to rack
CL8-2V-50-R/2(X/2)	125	2,8	50	1/4λ	8	8,15	19"
CL8-4V-50-R/2(X/2)	125	3,2	50	1/4λ	8	15,7	19"
CL8-6V-50-R/2(X/2)	125	3,5	50	1/4λ	8	23,9	ready
CL8-8V-50-R/2(X/2)	125	3,8	50	1/4λ	8	31,4	ready
CL8-2V-125-R/2(X/2)	125	2,8	125	1/4λ	8	9,6	19"
CL8-4V-125-R/2(X/2)	125	3,2	125	1/4λ	8	18,3	19"
CL8-6V-125-R/2(X/2)	125	3,5	125	1/4λ	8	28	ready
CL8-8V-125-R/2(X/2)	125	3,8	125	1/4λ	8	36,5	ready
CL8-2V-300	125	2,8	300	1/4λ	8	11	19"
CL8-3V-300	125	3	300	1/4λ	8	16,3	19"
CL10-2V-50-R/2(X/2)	100	2,6	50	1/4λ	10	9,5	ready
CL10-4V-50-R/2(X/2)	100	2,8	50	1/4λ	10	18,3	ready

CL10-6V-50-R/2(X/2)	100	3,4	50	1/4λ	10	27,8	ready
CL10-8V-50-R/2(X/2)	100	3,6	50	1/4λ	10	36,5	ready
CL10-2V-125-R/2(X/2)	100	2,6	125	1/4λ	10	11	ready
CL10-4V-125-R/2(X/2)	100	3,2	125	1/4λ	10	20,9	ready
CL10-6V-125-R/2(X/2)	100	3,4	125	1/4λ	10	31,6	ready
CL10-8V-125-R/2(X/2)	100	3,6	125	1/4λ	10	41,7	ready
CL12-2V-50-R/2(X/2)	75	2,5	50	1/4λ	12	17	on floor
CL12-4V-50-R/2(X/2)	75	2,8	50	1/4λ	12	34,2	on floor
CL12-6V-50-R/2(X/2)	75	3	50	1/4λ	12	52,8	on floor
CL12-8V-50-R/2(X/2)	75	3,2	50	1/4λ	12	70	on floor

One should not let go an opportunity to implement cavity transmitter combiners, if frequency separation enables this. This will considerably save radio signal energy, which will be spent in antenna, not in ballast load. Besides, cavities will provide high emission spectrum clearance of your transmitters, reduce noise and spurious radiation, influencing favourably on the air on the whole.

Transmitter combiners modular design enables to add additional channels or units for system expansion practically without any insertion loss.

Using high-Q cavities and managing insertion loss, we achieve extremely low power loss of signal combining. Complete range of various design cavities and ferrite isolators for various throughputs offers you an opportunity to select transmitter combiner with the best price/loss ratio, planing any antenna-feeder equipment configuration.

Submit our engineers with information about frequency plan, power input and output and possible antennas layout and they will help you to determine which transmitter combiner to select.

The combiners of Regular (R) class provide an operation of the transmitting link in temporal regime of exploitation with TX/RX =1:5, i.e. when the working load onto the transmitters of your system is not high. The combiners of Extreme (X) class are being applied in the case when repeaters operate with enhanced load (up to 100% of the cycle). These are more expensive and highly reliable products with the valves based upon the radiators (which do not allow the ferrites to become overheated) and for massive carrying out (external) loads.

**Dependence of loss on frequency separation TX-TX for CL8-4V-50 low loss transmitters combiners**

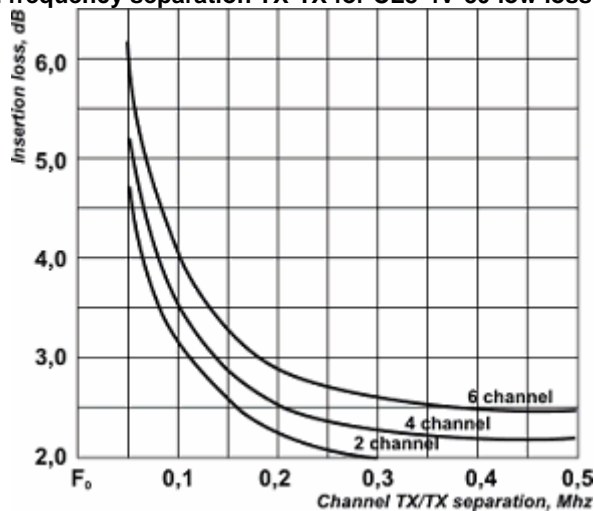

**Low loss transmitter combiner CL8-4V-50 electric diagram**

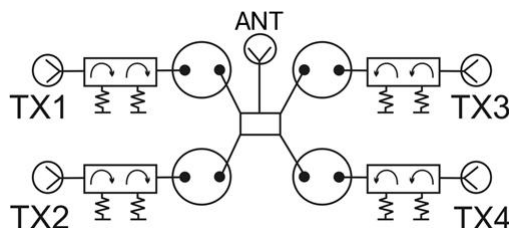



## 300-360 MHz Low-loss transmitter combiners

107497, Moscow Chernicinsky pr-d 7/1  
Tel.: (495) 775-43-19, 462-44-14  
Tel./fax: 462-44-14  
E-mail: radial@radial.ru  
www.radial.ru



### Electrical specifications

Model	CL10-2A-50	CL10-4A-50	CL10-6A-50	CL10-8A-50
Operating frequency band, MHz			300-360	
Insertion loss @ min. space, dB	3,2	3,6	3,9	4,2
Min. space TX/TX, kHz			200	
Impedance, Ohm			50	
Isolation TX-TX not less, dB			75	
VSWR, not more than			1,5	
Input power, W			not more than 50	
Temperature range, °C			-30 to +60	
Cavity electrical length			1/4λ	

### Mechanical specifications

Model	CL10-2A-50	CL10-4A-50	CL10-6A-50	CL10-8A-50
Diameter of cavity, mm (ins.)			257 (10")	
Weight without rack, kg	6,6	12,4	19	24,9
Connector			N-female	
Mount to 24-inch rack			shipped with rack	

Inter-Kosketus Oy Company offers 10-inch cavity transmitter combiner, enabling to combine up to 16 transmitting channels on common antenna. Flexible combiner tuning system enables to combine channels with 150 kHz or larger pitch. Large frequency separation is preferred and it is possible if you have competent frequency plan.

Low loss transmitter combiner CL10-8A-50

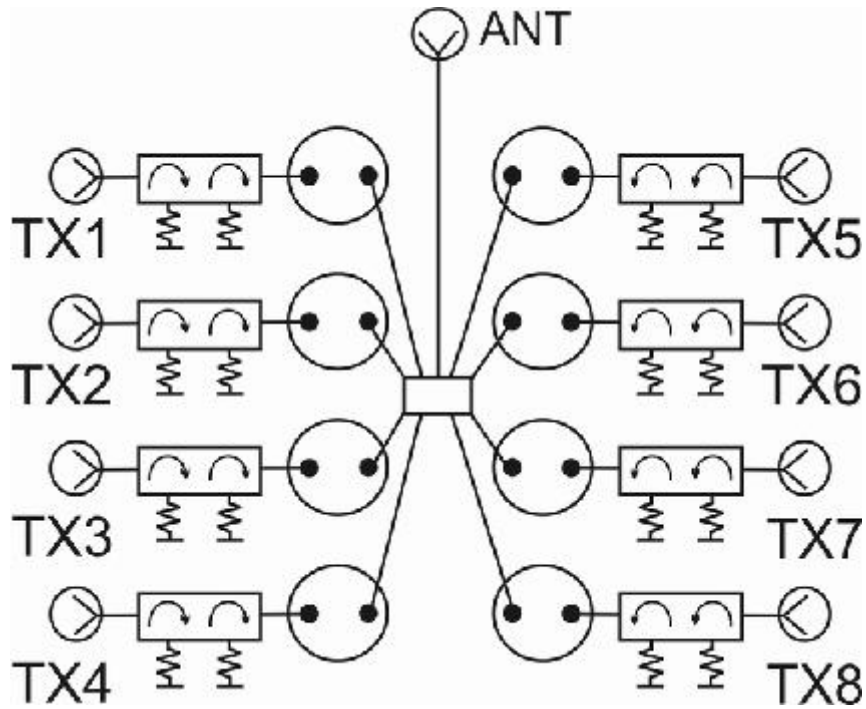

Dependence of loss on frequency separation TX-TX for CL10-A series transmitters combiners

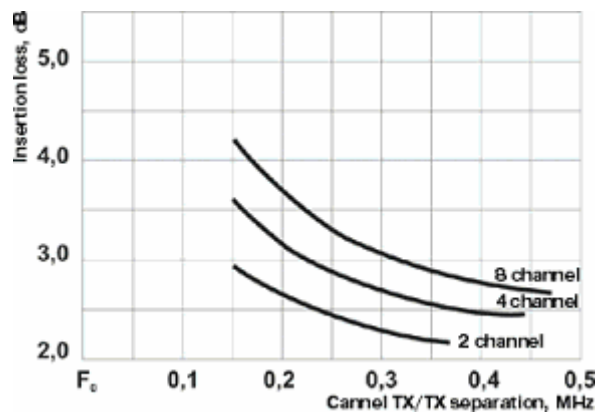



## 300-360, 400-490 MHz Low-loss transmitter combiners TETRA-A, TETRA-U

107497, Moscow Chernicinsky pr-d 7/1  
Tel.: (495) 775-43-19, 462-44-14  
Tel./fax: 462-44-14  
E-mail: radial@radial.ru  
www.radial.ru

TETRA-2U



TETRA-4U



### Electrical specifications

Model	TETRA-4A	TETRA-8A	TETRA-2U	TETRA-4U	TETRA-8U
Operating frequency band, MHz	300-360	300-360	400-490	400-490	400-490
Impedance, Ohm			50		
Number of channels	4	8	2	4	8
Min. space TX/TX, kHz			125		
Insertion loss @ dB@300kHz, dB	3	4.5	2.6	3.4	4.5
Input power, W			50		
Cavity electrical length			1/4λ		
Isolation TX-TX not less, dB			75		
VSWR			not more than 1,3		
Temperature Range			30°C to +60°C		

### Mechanical specifications

Model	TETRA-4A	TETRA-8A	TETRA-2U	TETRA-4U	TETRA-8U
Weight, kg	15.7	31.9	8	15.2	30.7
Connector			N-female		
Length/Width/Depth, sm	51x49x36	51x49x72	51x49x18	51x49x36	51x49x72

Taking into account the enhanced demand for 4 and 8 channel trunking systems a combiner has been worked out on the basis of four-resonator monoblock that is mounted at 19" stand. This has allowed to optimize the ratio volume/Q-factor for 19-inch construction solution. The combiners TETRA-A (at 300-360 MHz) and TETRA-U (at 400-490 MHz) represent a good solution for constructing base stations of the same name standard.

Dependance of loss on frequency separation TX-TX for TETRA-A and TETRA-U low loss transmitters combinets

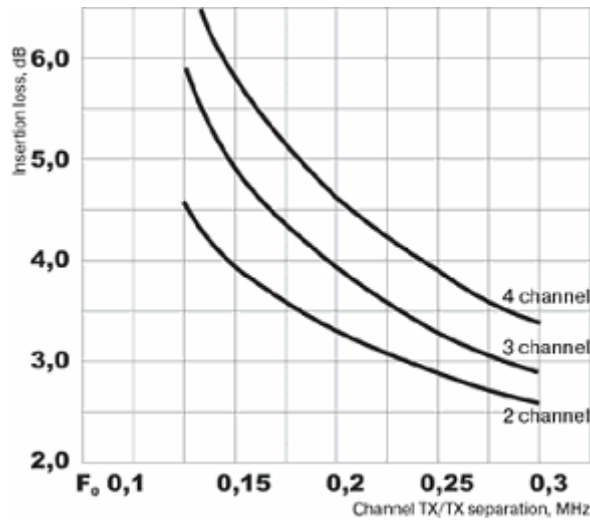

Low loss transmitter combiner TETRA-4A electric diagram

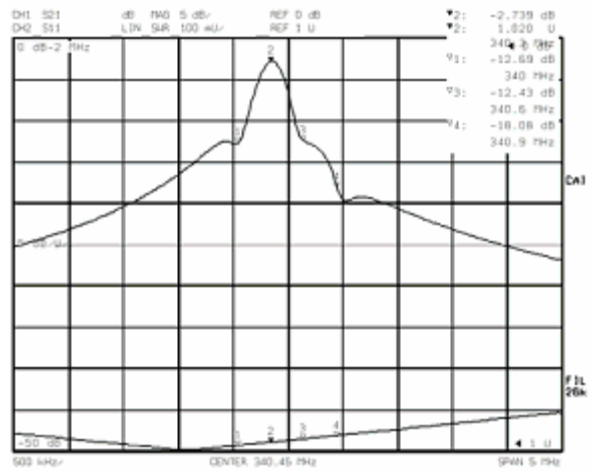
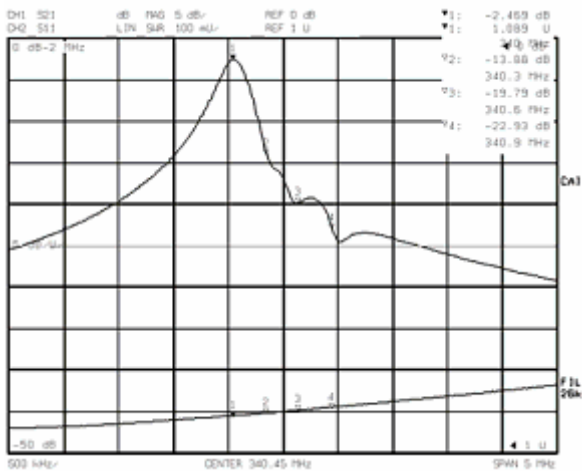



107497, Moscow Chernicinsky pr-d 7/1  
 Tel.: (495) 775-43-19, 462-44-14  
 Tel./fax: 462-44-14  
 E-mail: radial@radial.ru  
 www.radial.ru

## 400-490 MHz Low-loss transmitter combiners

CL8-4(2)U-50X/2



CL8-6(2)U-125R/2

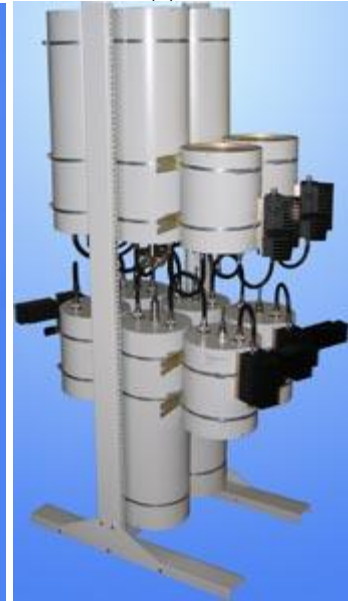

CL8-5UL-50X/2



### Electrical specifications

Model	Min. space TX/TX, kHz	Insertion loss @ min. space, dB	Input power, W	Cavity electrical length	Diameter of cavity, mm (ins.)	Weight without rack, kg	Mount to rack
CL8-2UL-50-R/2(X/2)	300	2,8	50	3/4λ	8	8,5	19"
CL8-4UL-50-R/2(X/2)	300	3,2	50	3/4λ	8	9,4	19"
CL8-6UL-50-R/2(X/2)	300	3,4	50	3/4λ	8	14,5	19"
CL8-8UL-50-R/2(X/2)	300	3,5	50	3/4λ	8	19	19"
CL8-2UL-125-R/2(X/2)	300	2,8	125	3/4λ	8	9,6	19"
CL8-4UL-125-R/2(X/2)	300	3,2	125	3/4λ	8	18,3	19"
CL8-6UL-125-R/2(X/2)	300	3,4	125	3/4λ	8	28	ready
CL10-2UL-50-R/2(X/2)	200	3,2	50	3/4λ	10	9,5	ready 24"
CL10-4UL-50-R/2(X/2)	200	3,6	50	3/4λ	10	18,3	ready
CL10-6UL-50-R/2(X/2)	200	4	50	3/4λ	10	27,8	ready
CL10-8UL-50-R/2(X/2)	200	4,2	50	3/4λ	10	36,5	ready
CL10-2UL-125-R/2(X/2)	150	3,2	125	3/4λ	10	11	ready

CL10-4UL-125-R/2(X/2) 150	3,6	125	3/4λ	10	20,9	ready
CL10-6UL-125-R/2(X/2) 150	4	125	3/4λ	10	31,6	ready
CL10-2UL-300	150	3	3/4λ	10	12,5	ready
CL10-3UL-300	150	3,2	3/4λ	10	18,3	ready

If you were lucky to acquire frequencies with respectable separation between transmitting channels (not less than 200 kHz), then it is better to use low loss transmitter combiner in multichannel system, definitely. This will considerably save radio signal energy, which will be spent in antenna, not in ballast load.

Besides, cavities will provide high emission spectrum clearance of your transmitters, reduce noise and spurious radiation, influencing favourably on the air on the whole. Transmitter combiners modular design enables to add additional channels or units for system expansion and practically without any insertion loss.

Using high-Q cavities and managing insertion loss, we achieve extremely low power loss of signal combining. Complete range of various design cavities and ferrite isolators for various throughputs offers you an opportunity to select transmitter combiner with the best price/loss ratio planing any antenna-feeder equipment configuration. Submit our engineers with information about frequency plan, system power input and output, and possible antennas layout and they will help you to determine which transmitter combiner to select.

The combiners of Regular (R) class provide an operation of the transmitting link in temporal regime of exploitation with TX/RX =1:5, i.e. when the working load onto the transmitters of your system is not high. The combiners of Extreme (X) class are being applied in the case when repeaters operate with enhanced load (up to 100% of the cycle). These are more expensive and highly reliable products with the valves based upon the radiators (which do not allow the ferrites to become overheated) and for massive carrying out (external) loads.

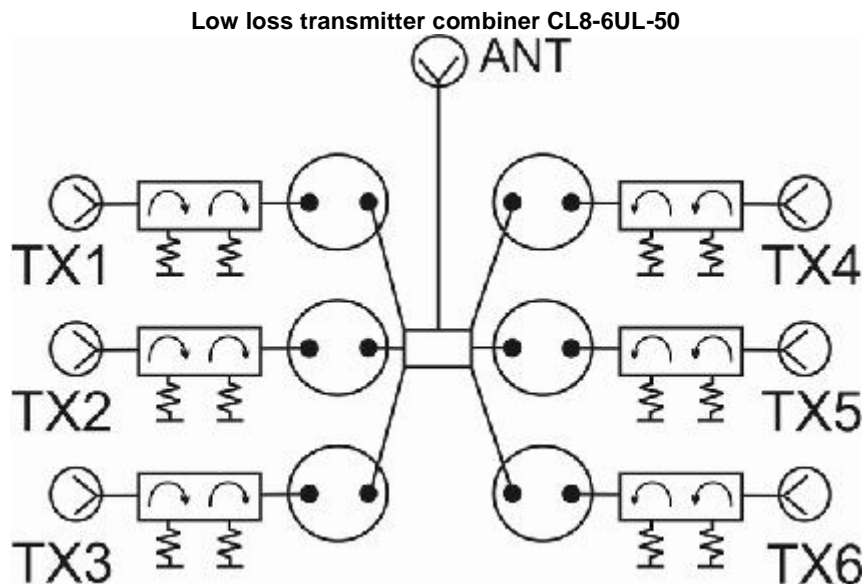

**Dependance of loss on frequency separation TX-TX for CL10-UL series transmitters combinets**

